



Note: this drawing illustrates the basic rail configuration and measurements for the NSK SH45 "combo" packages offered by Automation Overstock.

- Here is what you get when you purchase one of these pre-boxed combos:
- >> TWO pieces of 45mm rail measuring 825mm in length
- >> FOUR flange-style carriages (two carriages will be mounted on each rail).

We do NOT have additional rail available. It is possible to butt these combos end-to-end to get longer travel. For example, you can put two of them together to get 1650mm. This is not a true butt joint because the "P" dimension of the mounting holes will not be maintained at 105mm. Instead, at joints the "P" measure will be 90mm.

www.automation-overstock.com

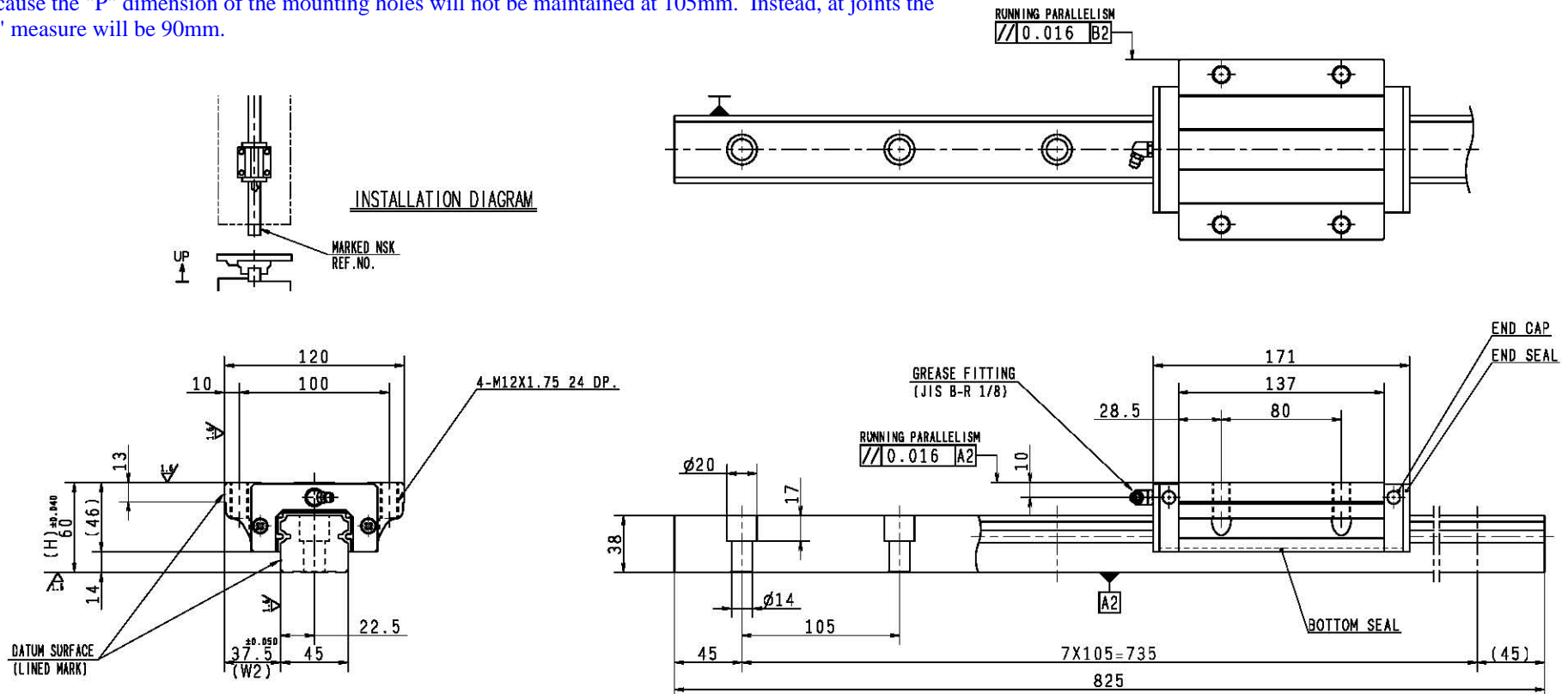

ASSEMBLY ACCURACY		L INEAR GUIDE SPEC.		PROPOSAL FOR		CUSTOMER'S DWG. NO.	
VARIATION OF MOUNTING HEIGHT (A PAIR OF RAILS, ALL SLIDES) H : 60	0.015	MATERIAL		MODEL NO.		SH45GL	
VARIATION OF LATERAL WIDTH (REFERENCE RAIL ONLY) W2 : 37.5	0.020	END CAP	POM	ACCURACY GRADE & PRELOAD	P623		
DYNAMIC FRICTION FORCE DATA		END SEAL	SEC+NBR	BALL DIAMETER	7.9375(5/16)		
PRELOAD	4600 N	RECOMMENDED TORQUE OF BOLTS(CASE OF SCM)		BASIC LOAD RATING, DYNAMIC	94500 N		
TOLERANCE OF FRICTION FORCE	16.7 ~ 30.5 N	BOLT NO.	TIGHTENING TORQUE N·m	BASIC LOAD RATING, STATIC	175000 N		
SEAL FRICTION FORCE	Max. 16.7 N	M2	0.27	M6	8.6		
MEASURING LUBRICATION	PRE-PACKED GREASE	M2.3	0.38	M8	22		
		M2.5	0.58	M10	43		
		M3	1.06	M12	76		
		M4	2.5	M14	122		
		M5	5.1	M16	196		
		LUBRICATION		Exxon Ronex MP Grease			
APPLICATION				HARDNESS OF BALL TRACK		HRC58~63	
APR'VD				NUMBER OF BALL SLIDES PER RAIL		2	
CHECKED				NUMBER OF BATTING RAILS			
DESIGNED				DATE			
DRAWN				NSK REF. NO. SH450825GLC2W01P63			
				NSK DWG. NO.			